

Treffler Milling Machinery

QUALITY STARTS WITH MILLING!

Flockomat
Absolutely dust-free.

- ✓ Absolutely dust-free
- ✓ Infinitely adjustable
- ✓ Thick- and thin-rolled flakes
- ✓ Accurate-to-the-gram production

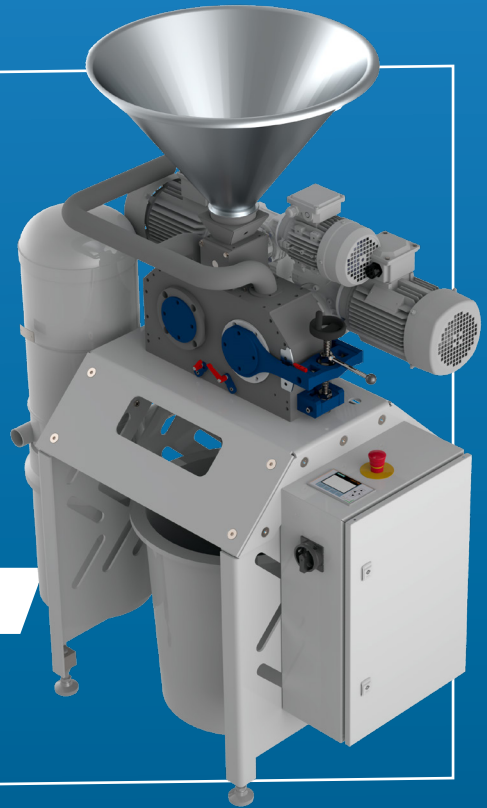

Treffler Flakomat. Singling out grain. Freshly flaked.

High-quality flakes for healthy muesli or as decoration. Flaked (pseudo) grains have many uses: for bakers, millers or farm marketers, the dust-free flaking plant is the answer to maintaining the excellent quality of the food.

DESIGN OF THE FLAKOMAT

What makes the Flakomat so special?

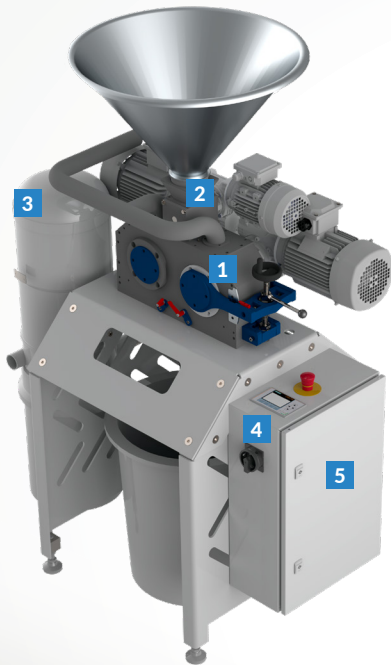

1 Mode of operation

Two profiled rollers are driven at a ratio of 1:1 to ensure evenly flaked material. The gap between the rollers can be adjusted as required from 0.01 mm to 5 mm.

2 Feed-in

The food-safe hopper is equipped with a magnetic separator. The material to be ground is continuously fed in by the electric volume-dosing system.

3 Extraction

A vacuum regulator can be used to determine how much fine flour the flakes should contain.

4 Fully automatic control

Full and empty indicators shut the machine down as required, so that continuous monitoring of the machine is not necessary.

5 Installation options

The Flakomat can be integrated into fully automatic systems. It can also be installed on a floor plate together with the Shrotomat and a dust extraction system.

FLAKOMAT TECHNICAL DATA

Technical data

FLAKOMAT 100

Output: 5.0kW
Weight: approx. 350kg
Roller width: 100mm

Required connection voltage: 400V 16A
Dimensions (LxWxH): 1.2x0.8x1.67 m

FEED MATERIAL

In addition to common varieties of grain, pseudo grains can also be processed.



Spelt



Oats



Quinoa



Millet